

Design and Implementation of an Automatic Material Handling System Using Petri Nets

Myoung-Sam Ko

School of Electrical Engineering

Seoul National University

San56-1, Shinlim-dong, Kwanak-gu, Seoul, Korea

Jongwon Kim

School of Mechanical Engineering

Seoul National University

San56-1, Shinlim-dong, Kwanak-gu, Seoul, Korea

Abstract - This paper presents the problem definition and the related research activities on the modeling, simulation, design and implementation of an automatic material handling system in a batch production environment. The colored and timed Petri nets are used to model and simulate the automatic material handling system. The Petri net modeling and simulation enable the determination of the design parameters of an automatic guided vehicle and an automatic storage/retrieval system, and also the estimation of the expected performance capability of the whole system. Finally, the whole system has been implemented for a specific batch production line. The comparison of the performance capability expected by the Petri net simulation and that measured from the real-time running of the whole system shows a good agreement.

I. INTRODUCTION

Manufacturing systems used to produce the products are usually classified as mass production and batch production on the basis of the batch size, that is, the quantity produced at one time. Although the products of mass production are evident, mass production accounts for a small portion of most developed countries' total manufactured output. The major part of the manufactured output, accounting for more than 70%, is produced by batch production methods [1]. However, batch production, which applies to the manufacture of many different parts with relatively small batch sizes, follows no invariable routings, requires more general purpose equipment, involves greater unit costs and is less automated. Hence, there are inevitable delays and problems.

The motivation of this paper actually stems from the traditional situation of the drug dispensary system of Korean general hospitals. The medical doctors of the hospital list the prescriptions and transfer those to the hospital's own dispensary room to be filled. The pharmacists make up the prescriptions based on several different process groups, and then deliver the drugs to the patients waiting outside the dispensary room in the hospital. The inherent problems of batch production exist in this dispensary system since the daily number of the prescriptions reaches 1,200 or more, and to make the situation worse, they are different from each other in general since the prescription is made to each different patient. This is one of the extreme cases of small-batch-size and many-different-part production. The natural consequence is the long waiting time, averaging more than one hour, which the patients have to suffer outside the

dispensary room.

To tackle this problem, it has been decided to design, manufacture and implement an adequate automatic material handling system into the dispensary room to shorten the overall delays of batch production. The automatic material handling system is classified into the material transporting facilities such as an automatic guided vehicle (AGV) system, the material buffering facilities such as an automatic storage and retrieval system (AS/RS), and the point-on-production (POP) data processing system such as a data communication network of bar-code terminals. It has been verified in this paper that the automatic material handling system reduces significantly the overall lead-time of the dispensary system:

- (1) by eliminating the indirect operations of the manual delivery of materials such as prescriptions, drugs, envelopes, *etc.* between various drug preparation processes,
- (2) by reducing the moving distances of the pharmacists in charge of inspection, and
- (3) by eliminating the indirect operations of the manual sorting, storage, retrieval and distribution of finished drugs

The design of an AGV system and an AS/RS for the given dispensary system includes the determination of the following design parameters:

- (1) the required maximum speed of the AGV with the expected utilization rate,
- (2) the optimal AGV batch size which the AGV delivers at a time,
- (3) the required maximum speed of the stacker crane of the AS/RS with the expected utilization rate, and
- (4) the expected distribution of the lead-time which each prescription will take to be filled completely.

To determine the optimal values of the design parameters, an adequate methodology is needed at the design stage for modeling and simulation of the whole system which results from the integration of the resources of the given dispensary system with the automatic material handling systems to be implemented. Maxwell and Muckstadt[2] studied the estimation algorithm for determining the minimum number of the required vehicles by using the transportation formulation method. Mahadevan and Narendran[3] used an analytical model to obtain the number of the required AGV units, and

evaluated various dispatching rules by a series of simulation studies. Vosniakos and Mamalis[4] examined the procedures for designing the AGV guide path layout and the routing algorithms. Mahadevan and Narendran[5] presented an integer programming formula for obtaining the optimal batch size of an AGV based material handling system in a FMS environment.

On the other hand, recently, the Petri nets have been applied to the manufacturing system design. Peng and Brussel[6] demonstrated a new approach that integrates the modeling, simulation and control of the flexible assembly cell by using colored and timed Petri nets. Zeng, Wang and Jin[7] constructed a set of formal definitions of colored and timed Petri nets for modeling AGV systems and for developing the procedures of detecting the vehicle routing conflict. Teng and Black[8] used the Petri net technique to build up the control system of the machining cell which can handle just-in-time production features. It has been shown that the Petri net is an efficient tool for modeling and analyzing discrete event systems.

In this paper, the colored and timed Petri nets are used to model the automated dispensary system. The drugs in the dispensary system are grouped into 12 groups according to the routing. The tokens of 12 different colors are used to identify each drug group. A delay time is associated with each timed transition. When the transition fires, it takes the assigned (determined or stochastic) delay time to complete the firing. The Petri net models for the routings of different drug groups, for the AGV system, and for the AS/RS are constructed, and then the whole integrated Petri net model is simulated according to the scheduled prescription input rate and volume.

This paper is organized as follows: The subsequent section describes the problem definition to be solved. The Petri net models are then presented in section 3. The section 4 shows the Petri net simulation results and the determined parameter values of the automatic material handling systems. The section 5 introduces the practical aspects experienced when implementing the whole system in the specific general hospital. Finally, in section 6, a brief discussion and concluding remarks are given.

II. PROBLEM DEFINITION

The basic schematic layout of the automatic material handling systems for the given dispensary system is shown in Fig.1. The whole production line is composed of N process groups, P_1, \dots, P_N , an input station P_0 , a buffer station P_{N+1} , and an output station P_{N+2} . It is assumed that total of m_i machines are assigned to each of the process groups P_i ($i=1, \dots, N$). The process groups are distributed along the AGV track, however, the optimal placement of the process groups is initially unknown at the design stage. The number of the AGV installed should be one due to the space limitation. There exists an AS/RS between the buffer station P_{N+1} and the output station P_{N+2} .

The products are assumed to be classified into M groups, D_1, \dots, D_M , based on the routings in which the products are manufactured or processed. The total number

of products is n_{TTL} , and the portion of the products which belong to the product group D_j ($j=1, \dots, M$) is assumed to be x_j percent of the total number of products n_{TTL} . The routing of each product group begins with the input station P_0 and ends at the buffer station P_{N+1} . Each product group has its own routing $\{R\}_j$ between P_0 and P_{N+1} , which consists of any sequential combination of P_i ($i=1, \dots, N$). The standard processing time $\{t_i\}_j$ required at each P_i ($i=1, \dots, N$) for each D_j ($j=1, \dots, M$) is assumed to be given.

Under the aforementioned conditions, the following problems are to be solved:

- (1) To obtain the optimal batch size b which is the maximum number of products which AGV should transport between stations during each movement. All the products in a batch belong to the same product group.
- (2) To calculate the required AGV speed v_{AGV} and to estimate the AGV utilization rate u_{AGV} ,
- (3) To calculate the required speed v_{ASRS} of the AS/RS stacker crane and to estimate the AS/RS utilization rate u_{ASRS} , and
- (4) To estimate the total lead-time distribution $LT(D;x)$ for the given production volume of x_j for each D_j ($j=1, \dots, M$) to be completed from P_0 to P_{N+2} .

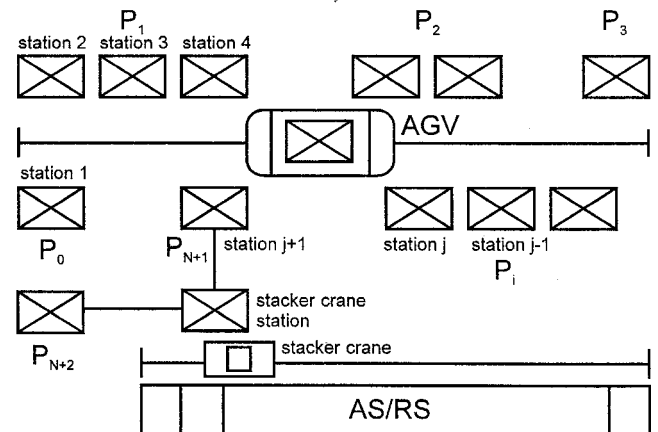

Fig.1 Basic Schematic layout of the automatic material handling systems for the given dispensary system

III. PETRI NET MODELS

A specific case study has been applied to the dispensary system of the Kangnam Catholic Medical Center in Seoul, Korea. In this case, the total number of products are daily 1200 on the average ($n_{TTL}=1200$), which can be classified into 12 groups ($M=12$) according to the routing. Table 1.a shows the classification of the 12 groups in detail. Each group has its own routings $\{R\}_j$ and the statistics on the daily production volumes. However, it should be noted that the processing time of each drug is different with other drugs even if they belong to the same product group, that is, even if their routings are the same. In this case, the total process groups are six ($N=6$) plus input station (P_0)

and buffer station (P_7). The process times at each process group are measured. Table 1.b shows the statistics.

Each material flow in the automated dispensary room begins with the dispatching of each prescription by the head pharmacist. The head pharmacist puts the prescription in a container and calls for the AGV to dispatch the prescription to the next process group. At every process group, the prescription is partially filled and moved to the next process group until the routing reaches the final buffer station. Then, the finished drug is packaged and announced automatically to the patients outside the dispensary room that it is ready for picking up. After a certain amount of delay time, the packaged drug is moved into the input station of the AS/RS. If the patient has already replied for the announcement to pick up, then the package is by-passed to the delivery counter, otherwise it is stored automatically into the empty rack of the AS/RS by the stacker crane.

Table 1 Product and process groups in case of the dispensary room of Kangnam Catholic Medical Center

(a) Classification of the product groups

Product Group	Routings $/R/j$				Production Volume (daily average)	
	1	2	3	4	number	percent (%)
D1	P0	P1	P7		216	18.0
D2	P0	P2	P7		348	29.0
D3	P0	P6	P7		228	19.0
D4	P0	P5	P7		132	11.0
D5	P0	P3	P4	P7	60	5.0
D6	P0	P2	P3	P7	60	5.0
D7	P0	P2	P5	P7	60	5.0
D8	P0	P5	P6	P7	60	5.0
D9	P0	P4	P7		12	1.0
D10	P0	P3	P7		12	1.0
D11	P0	P3	P6	P7	4	0.3
D12	P0	P2	P6	P7	8	0.7
Total					1200	100

(b) Classification of the process groups

Process Group and Description		Sub-operation	Number of machines	Processing time (sec)
				mean \pm std. dev.
P0	Prescription Distribution		2	20 \pm 10
P1*	Automatic Tablet Counting Machine	1	1	60 \pm 30
P2*	Manual Tablet Packaging Machine	1	3	108 \pm 54
		2	3	70 \pm 45
P3	Liquid-type Drug Preparation		1	108 \pm 54
P4*	Drug preparation for Pediatric	1	1	112 \pm 61
		2	1	31 \pm 69
P5	Drug Preparation for External Application		1	16 \pm 9
P6*	Mass-Counting Station	1	2	112 \pm 61
		2	1	31 \pm 69
P7	Packaging for Storage		1	7 \pm 5

* Process groups consist of two sequential sub-operations

From the material flow described above and the tables given in Table 1, the colored and timed Petri net model for the whole automated dispensary system is given in Fig.2. The token of different color identifies each of the drug groups D_1, \dots, D_{12} . The timed transition represents the delay time at each of the process groups P_0, \dots, P_6 , input

station P_0 and buffer station P_7 . Since there are a lot of places and transitions in the whole Petri net models, two subnet models are used for simplicity in the model shown in Fig.2: The subnets of the AGV system are labeled as $SN\#AGV1 \sim SN\#AGV24$ in Fig.2. Each subnet presents each transfer of drugs by the AGV from one station to another as shown in Fig.3 in detail. The subnet of the AS/RS is labeled as $SN\#ASRS$ in Fig.2. Figure 4 shows the detailed Petri-net of the AS/RS. Each completed drug is stored in one of the boxes at the buffer station. There are four sizes of boxes: small, medium, large and huge sizes. Hence, the racks of the AS/RS are also divides into four areas which can accommodate the four different sizes of boxes respectively. The Petri-net of the AS/RS in Fig.4 shows the four different cases accordingly.

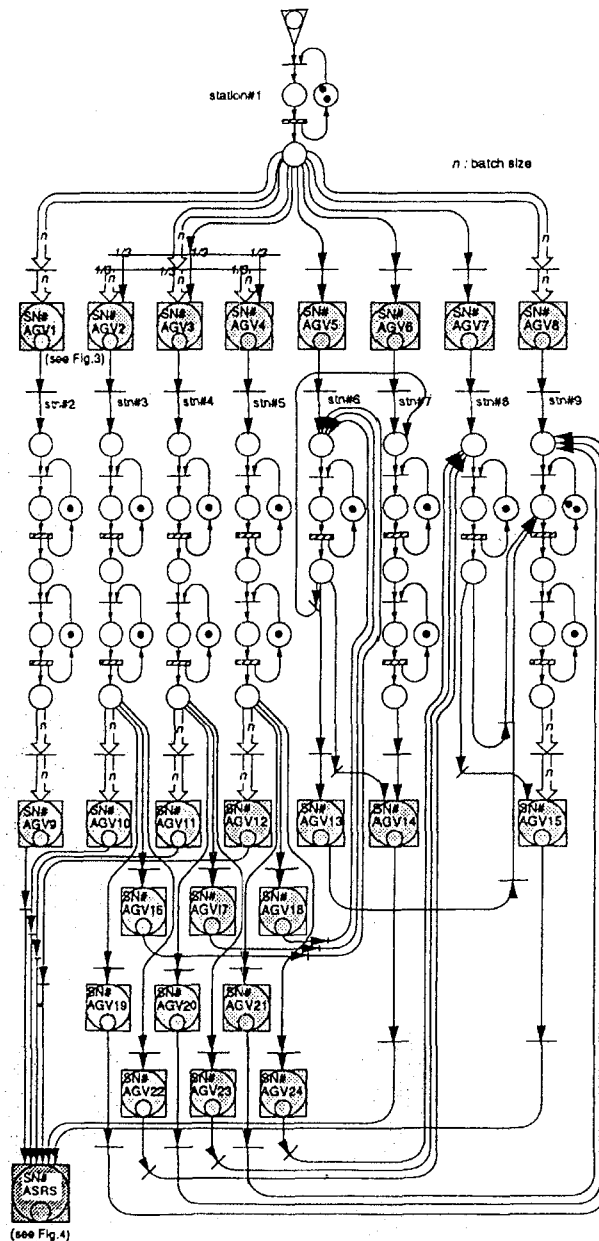

Fig.2 Petri net model for the given automated dispensary system

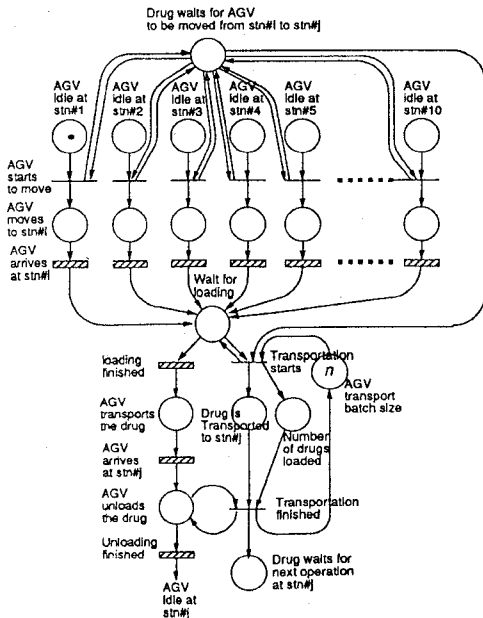

Fig.3 Petri net model for the AGV system implemented in the dispensary system

IV. PETRI NET SIMULATION FOR SELECTING DESIGN PARAMETERS

A simulation engine has been implemented by using the Petri net models presented in Fig.2. Since the process groups are manually operated, the AGV call signal at each process group is also handled by the pharmacist. Hence, the dispatching of the AGV is based on the first-call first-served rule. It is to be noted that the total number of prescriptions per day is assumed to be $n_{TTL}=1,200$ for simulation and that the input rate of prescriptions supplied into the dispensary system varies during the daytime period which results in two peaks as shown in Fig.5.

The larger the batch size of the AGV delivery is, the longer becomes the delay time which will take for the jobs to be done together. On the other hand, if the batch size is too small, the frequent movement of the AGV causes the longer delay time as the AGV utilization rate reaches higher value. From Table 1, the first four product groups, D_1, D_2, D_3 and D_4 , take the 80% of the whole production volume. Hence, it has been decided that first four product groups are served by the AGV with an optimal AGV batch size and the others with the size of one. The simulation using Petri net models has been carried out varying the batch size for the first four groups to find an optimum value. The simulation result is shown in Fig.6. The optimal batch size b for the AGV delivery is selected to be four since it yields the minimum mean lead-time.

To find out the required range of the AGV speed v_{AGV} , the Petri net simulation has been done to obtain the results presented in Fig.7. It is very evident that the AGV speed v_{AGV} should be compromised to be 100 m/min. At this speed the simulation results shows that the AGV utilization rate u_{AGV} is 65% on the average and 100% in instantaneous peak period as in Fig.8. The placement or

layout of $P_i(i=1, \dots, N)$ along the AGV path has been fixed before the modeling stage due to the utilities problems for each process group such as the supply sources of water, compressed air, electric power, etc. The arbitrary placement of the process groups was impossible.

The Petri net simulation has been also carried out for selecting the required speed v_{ASRS} of the AS/RS stacker crane and for estimating the AS/RS utilization rate u_{ASRS} . The results are shown in Fig.9 and Fig.10, respectively. The speed of stacker crane should be decided for AS/RS not to be a bottleneck of the whole system. So the required x-axis speed of the AS/RS stacker crane are determined to be 40 m/min from Fig.9 considering the safety factor. At this speed the simulation results show the AS/RS utilization rate u_{ASRS} is 35% on the average and 60% in instantaneous peak period as in Fig.10. The buffer size r for the AS/RS has been fixed at 212 cells due to the installation space constraints.

Finally, the total lead-time distribution $LT(D;x)$ for the given production volume of x_j for each $D_j(j=1, \dots, 12)$ to be completed from P_0 to P_8 is simulated. The results are shown in Fig.11. The waiting time of the patients outside the dispensary room has been estimated to be reduced to 30 min or less on the average. This is a significant reduction compared to the previous waiting time of 60 min or more on the average before automation.

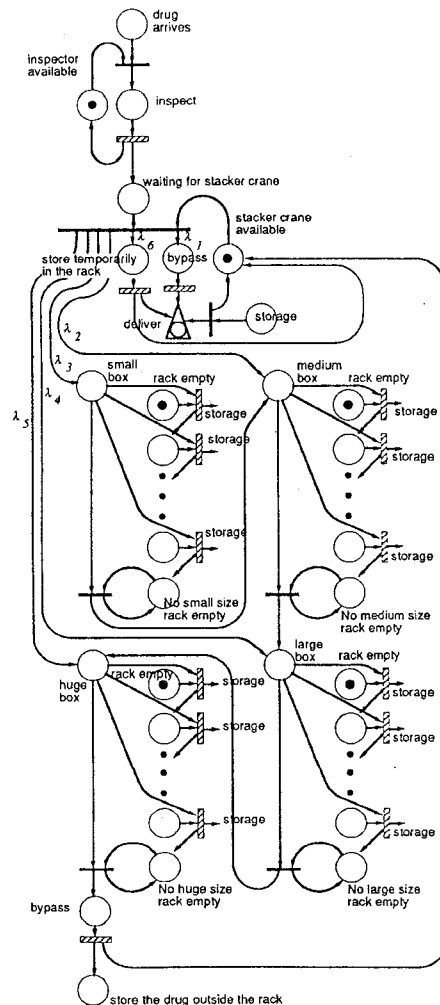

Fig.4 Petri net model for the AS/RS implemented in the dispensary system

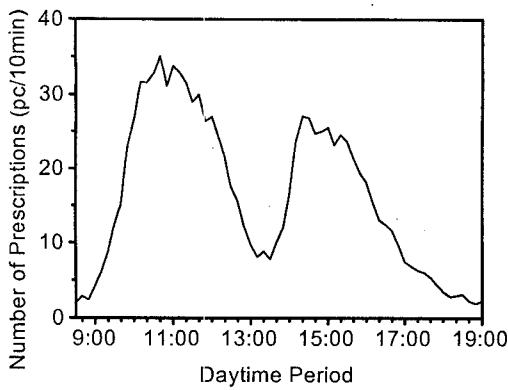

Fig.5 Daily variations of the input rate of the prescriptions supplied into the dispensary system

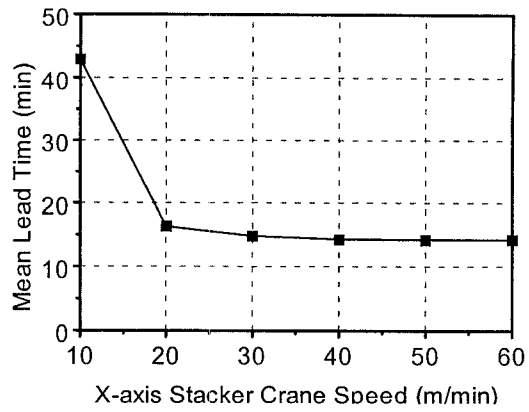

Fig.9 Petri net simulation result for selecting the required speed of the AS/RS stacker crane

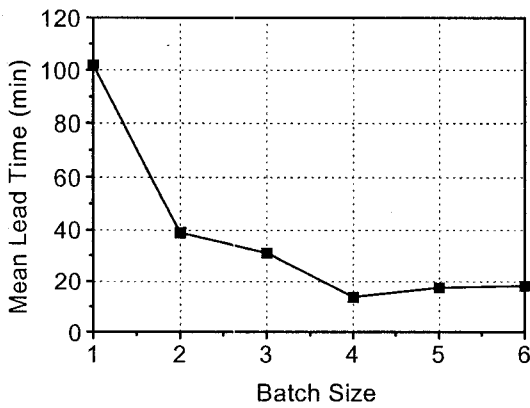

Fig.6 Petri net simulation result for selecting an optimal batch size for the AGV delivery

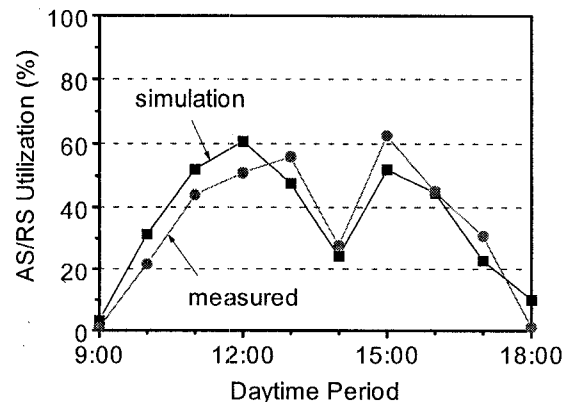

Fig.10 Petri net simulation result and the measured values of the AS/RS utilization rate

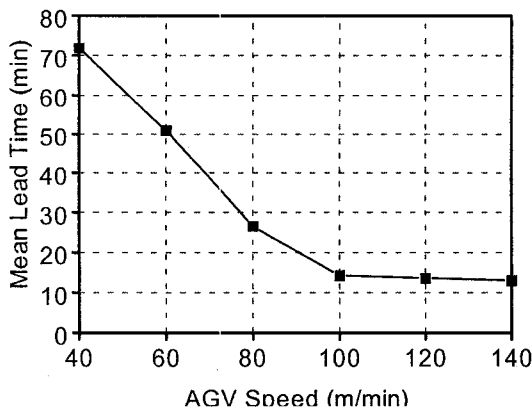

Fig.7 Petri net simulation result for selecting the required AGV speed

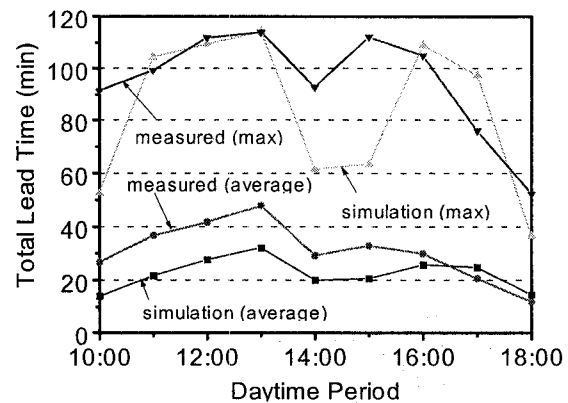

Fig.11 Petri net simulation result and the measured values of the total leadtime distribution

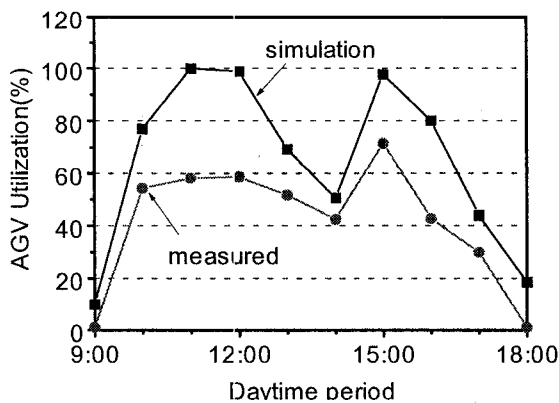

Fig.8 Petri net simulation result and the measured values of the AGV utilization rate

V. IMPLEMENTATION OF THE AUTOMATED DISPENSARY SYSTEM

The system layout implemented in the dispensary system of the Kangnam Catholic Medical Center in Seoul, Korea is shown in Fig.12. The real time operation of the system started from July 5, 1993.

The operation of the AGV system is controlled by the independent microprocessor-based main station, which is

linked to the microprocessor-based substations of the process groups through the ring topology communication network. The movement of the AS/RS stacker crane is controlled by an IBM compatible personal computer which is connected to the bar-code main terminal which accumulates the scanned information from five different bar-code scanners.

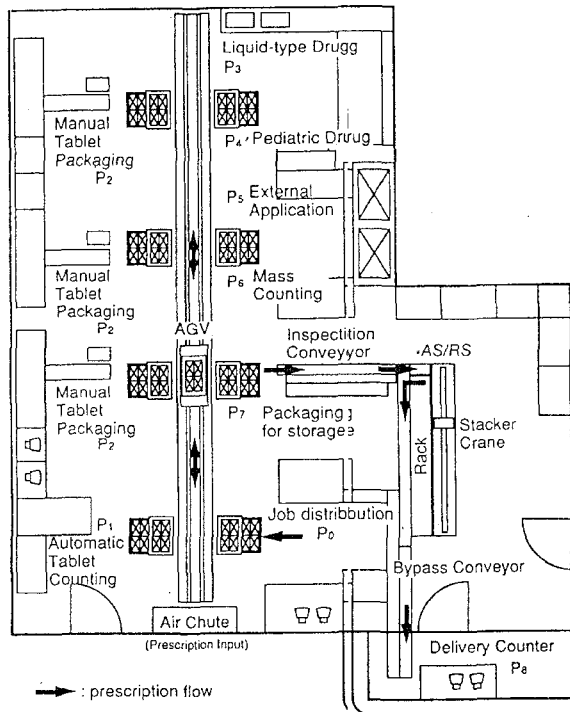

Fig.12 Layout drawing of the automated dispensary system implemented

Comparing the total lead-time measured in Nov., 1993 with that in May, 1991 when the system was not automated yields that the average total lead-time decreases 41% from 58 minutes to 34 minutes on the average even though the average number of prescriptions per a day increases 12.6% from 1,080 to 1,217. The measured utilization rate of the AGV system is much lower than that estimated by the Petri net simulation as shown in Fig.8. This is because the pharmacists still carry some of prescriptions to the process groups manually. The measured utilization rate of the AS/RS stacker crane shows a good agreement with that estimated by the Petri net simulation as shown in Fig.10. In this case the stacker crane is protected by the safety fence so that any human intervention is impossible.

Figure 11 shows the comparison of the measured total lead-time and that of the simulated results. It can be identified that the patterns of two curves are the same, but that the measured total lead-time is somewhat higher than the estimated lead-time by the amount of 10 min. on the average. This difference resulted mainly from the human factors, which brings out the difference between the actual process time taken for preparation of the drugs and that used in the simulation studies.

VI. CONCLUSIONS

In this paper, it has been verified that the design and implementation of the automatic material handling system in a batch production environment enables the reduction of the total production lead-time by eliminating the indirect manual operations of material delivery and storage/retrieval, and also by reducing the unnecessary moving distances of the operators.

A specific drug dispensary system of a general hospital has been chosen and automated as a small-batch-size and many-different-product production line. The colored and timed Petri net modeling and simulation methodology has been used to determine the design parameters of the AGV system and the AS/RS, and to evaluate the performance of the whole system at the design stage.

A real time system has been implemented and operated successfully. The measured and simulated results of the utilization rates of the AGV system and the AS/RS, and those on the total lead-time have shown good agreement comparatively, which can verify that the colored and timed Petri nets offer one of the efficient tools for modeling and analyzing even the automated batch production system.

VII. REFERENCES

- [1] Talavage, J. and R.G. Hannam, 1988, *Flexible Manufacturing Systems in Practice*, Marcel Dekker, Inc., New York, USA.
- [2] Maxwell, W.L. and J.A. Muckstadt, 1982, "Design of Automated Guided Vehicle Systems", *IIE Transactions*, Vol.14, No.2, 114-124
- [3] Mahadevan, B. and T.T. Narendran, 1990, "Design of an Automated Guided Vehicle-based Material Handling System for a Flexible Manufacturing System", *Int. J. Prod. Res.*, Vol.28, No.9, 1611-1622
- [4] Vosniakos, G.-C. and A.G. Mamalis, 1990, "Automated Guided Vehicle System Design for FMS Applications", *Int. J. Mach. Tools Manufact.*, Vol.30, No.1, 85-97
- [5] Mahadevan, B. and T.T. Narendran, 1992, "Determination of Unit Load Sizes in an AGV-based Material Handling System for an FMS", *Int. J. Prod. Res.*, Vol.30, No.4, 909-922
- [6] Peng, Y. and H. Van Brussel, 1994, "Modeling, Simulation, and Control of FMS Using Petri Nets", *Proc. of the 4th Int. Conference on CIM and Automation Technology*, Oct.10-12, RPI, Troy, USA, 248-253
- [7] Zeng, L., H.P. Wang and S. Jin, 1991, "Conflict Detection of Automated Guided Vehicles: a Petri Net Approach", *Int. J. Prod. Res.*, Vol.29, No.5, 865-879
- [8] Teng, S.H. and J.T. Black, 1992, "Petri Nets for Manufacturing Cell Control Operations", *Manufacturing Review*, Vol.5, No.2, 127-136